

# 772

## Soft Serve Freezer

Two Flavor

### Features

Offer all the popular soft serve variations from low or non-fat ice creams to custards, yogurt and sorbet in two separate flavors.

### Freezing Cylinder

Two, 7 quart (6.6 liter).

### Mix Hopper

Two, 20 quart (18.9 liter). Separate hopper refrigeration (SHR) maintains mix below 41°F (5°C) during Auto and Standby modes.

### Indicator Lights

Add Mix light alerts operator to add mix.

### Solid State Controls

Thermistor control precisely monitors temperature to maintain consistent quality.

### Standby

During long no-use periods, the standby feature maintains safe product temperatures in the mix hopper and freezing cylinder.

### Two Locking Casters

Front casters have a locking feature for operators to lock to maintain equipment in place. The locking casters can be released to move the equipment for cleaning.



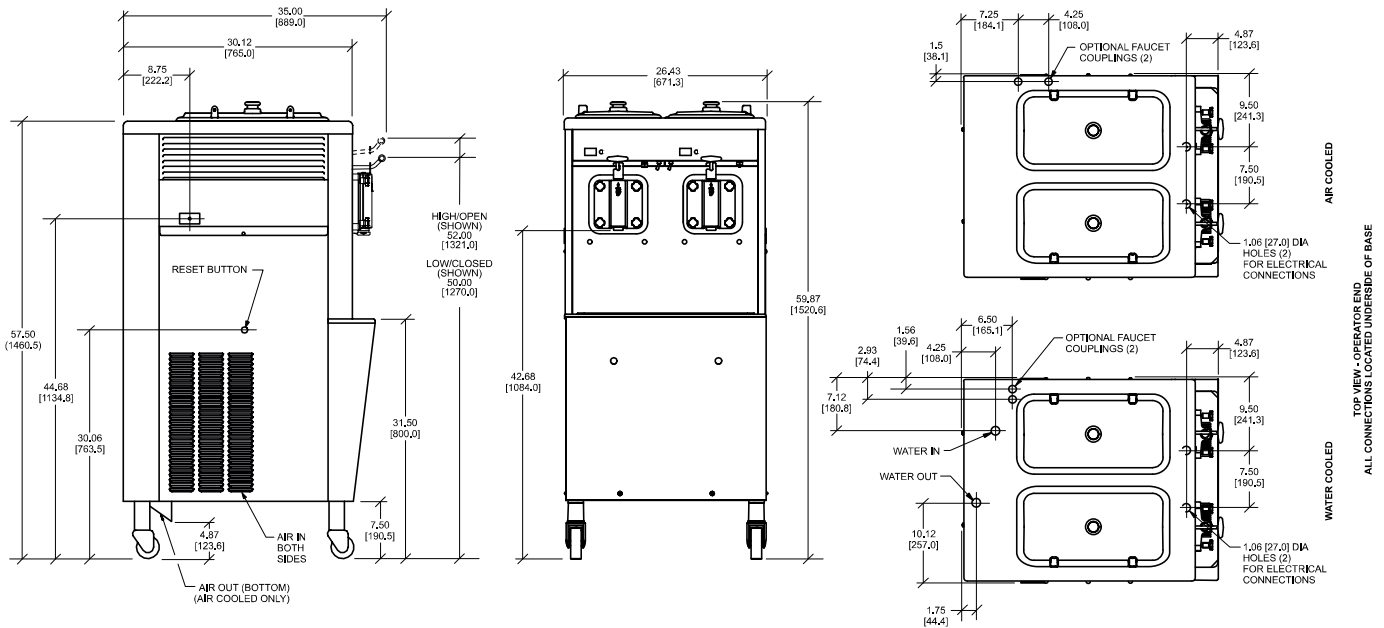

FIGURES IN BRACKETS INDICATE MILLIMETERS / DECIMAL DIMENSIONS EQUAL TO ( PLUS OR MINUS 1/16 INCH [1.5mm] ).

Weights	lbs.	kgs.
Net	630	285.8
Crated	700	317.5
	cu. ft.	cu. m.
Volume	46.2	1.3
Dimensions	in.	mm.
Width	26-7/16	672
Depth	35	889
Height	59-7/8	1521
Floor Clearance	7-1/2	191

\*Mounted on standard casters

Electrical	Maximum Fuse Size		Minimum Circuit Ampacity		Poles (P) Wires (W)
	Left	Right	Left	Right	
208-230/60/1 Air	35	30	29	25	2P 3W
208-230/60/1 Water	35	30	26	25	2P 3W
208-230/60/3 Air	20	15	18	14	3P 4W
208-230/60/3 Water	20	15	16	14	3P 4W
460/60/3 Air	15	12	13	9	3P 4W

This unit may be manufactured in other electrical characteristics and may have additional regulatory agency approvals. Consult the local Taylor Distributor for other electrical characteristics and agency approvals based on specific electrical and country requirements.

(For exact electrical information and approval marks, always refer to the data label of the unit.)

**Continuing research results in steady improvements; therefore, these specifications are subject to change without notice.**

**Bidding Specs**

Electrical: Volt \_\_\_\_\_ Hz \_\_\_\_\_ ph \_\_\_\_\_  
 Neutral: Yes No      Cooling: Air Water NA

Options: \_\_\_\_\_

**Specifications**

**Electrical**

Two dedicated electrical connections are required. See the Electrical chart for the proper electrical requirements. Manufactured to be permanently connected. Consult your local Taylor distributor for cord & receptacle specifications as local codes allow.

**Beater Motor**

Two, 2.0 HP.

**Refrigeration System**

Two, 9,500 BTU/hr. R404A.  
 Separate Hopper Refrigeration (SHR), One, 400 BTU/hr. R134a. (BTUs may vary depending on compressor used.)

**Air Cooled**

Minimum 3" (76 mm) around all sides. Install the deflector provided to prevent recirculation of warm air. Minimum air clearances must be met to assure adequate air flow for optimum performance.

**Water Cooled**

Water inlet and drain connections under side of base 3/8" FPT.

**Options**

- Cone Dispenser
- Faucet
- Hopper Locks
- Panel Spinner
- Syrup Rail Kit (side mount)

**Authorized Taylor Distributor**



750 N. Blackhawk Blvd.  
 Rockton, Illinois 61072  
[www.taylor-company.com](http://www.taylor-company.com)