

# C002

## Continuous Dispensing Batch Freezer

Two Flavor

### Features

Offer super premium frozen custard, low overrun ice cream, or sorbet in two separate flavors.

### Mix Hopper

Two, 20 quart (18.9 liter). Separate hopper refrigeration (SHR) maintains mix below 41°F (5°C).

### Indicator Lights

In order from top to bottom, separate lights indicate when mix is low, refrigeration on, pre-chill mode, and scraping/ejection motor on.

### Product Chute

Ribbon of frozen product flows down chute to separate dipping cabinet. Easily removable for cleaning or moving dipping cabinet.

### Mix Flow Regulator

Easy to read markings allow operator to dial in the correct amount of mix flowing into freezing cylinder for proper consistency. Adjusts for operation from the front, back, or side, depending on space requirements.



**Shown with separate dipping cabinet  
(Available through your local Taylor distributor)**

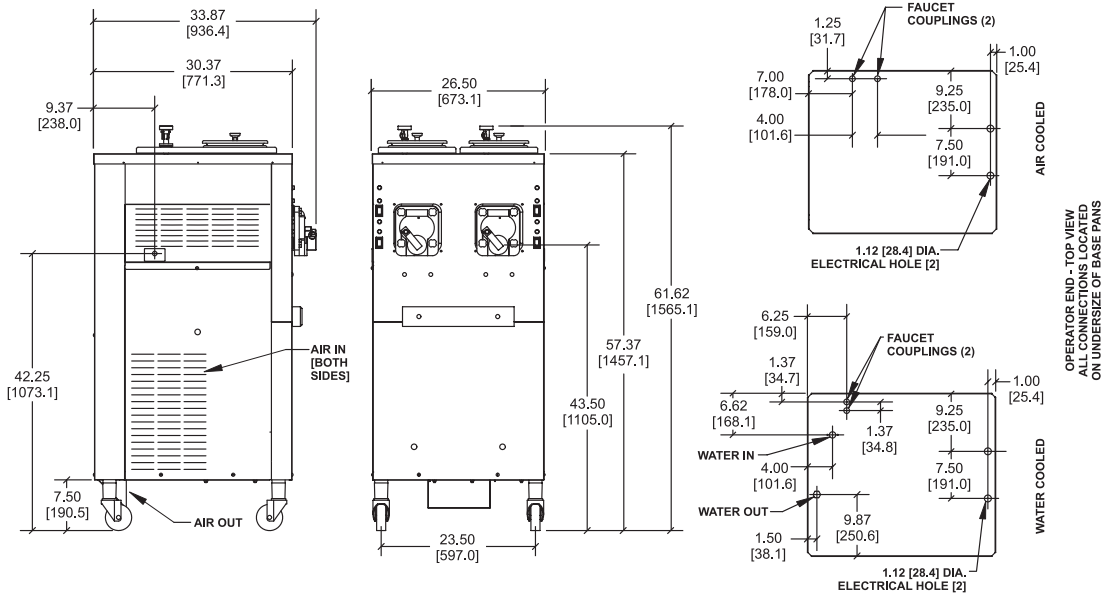

FIGURES IN BRACKETS INDICATE MILLIMETERS. DECIMAL DIMENSIONS EQUAL TO ( PLUS OR MINUS 1/16 INCH [1.5mm] ). \* WATER COOLED ONLY

Weights	lbs.	kgs.
Net	825	374.2
Crated	855	387.8
	cu. ft.	cu. m.
Volume	67.4	1.91
Dimensions	in.	mm.
Width	26-1/2	674
Depth	33-7/8	937
Height	61-5/8	1565
Floor Clearance	7-1/2	191

\*Mounted on standard casters

Electrical	Maximum Fuse Size		Minimum Circuit Ampacity		Poles (P) Wires (W)
	Left	Right	Left	Right	
208-230/60/1 Air	30	30	24	22	2P 3W
208-230/60/1 Water	30	30	24	22	2P 3W
208-230/60/3 Air	20	20	17	15	3P 4W
208-230/60/3 Water	20	20	17	15	3P 4W
380-415/50/3N~ Air	10	9	9	7	4P 5W

This unit may be manufactured in other electrical characteristics and may have additional regulatory agency approvals. Consult the local Taylor Distributor for other electrical characteristics and agency approvals based on specific electrical and country requirements.

(For exact electrical information and approval marks, always refer to the data label of the unit.)

**Continuing research results in steady improvements; therefore, these specifications are subject to change without notice.**

**Bidding Specs**

Electrical: Volt \_\_\_\_\_ Hz \_\_\_\_\_ ph \_\_\_\_\_  
 Neutral: Yes No      Cooling: Air Water NA

Options: \_\_\_\_\_

**Specifications**

**Electrical**

Two dedicated electrical connections are required. See the Electrical chart for the proper electrical requirements. Manufactured to be permanently connected. Consult your local Taylor distributor for cord & receptacle specifications as local codes allow.

**Scraping/Ejection Motor**

Two, 2.0 HP.

**Refrigeration System**

Two, 8,000 BTU/hr compressors (nominal rating). R404A. Separate Hopper Refrigeration (SHR), One, 400 BTU/hr. R134a. (BTUs may vary depending on compressor used.)

**Air Cooled**

Minimum 3" (76 mm) around all sides. Install the deflector provided to prevent recirculation of warm air. Minimum air clearances must be met to assure adequate air flow for optimum performance.

**Water Cooled**

Water inlet and drain connections under side of base 1/2" FPT.

**Options**

- Dipping Cabinet (Consult your local Taylor distributor)
- Width: 28-7/16" (722 mm)
- Depth: 17-3/4" (451 mm)
- Height: 37-1/2" (953 mm)
- Weight: 175 lbs. (79.4 kg)

Authorized Taylor Distributor



750 N. Blackhawk Blvd.  
 Rockton, Illinois 61072  
[www.taylor-company.com](http://www.taylor-company.com)