



TOTALLY DIFFERENT.



C812

Electric Two-Sided Grill

Features

One touch menu selection automatically provides accurate TIME, TEMPERATURE, and GAP settings for every product.

Programmable Controls

Microprocessor controls are programmable for simplified operator operation. Also offers flexibility for future menu items and product specification changes at the restaurant level.

Upper Platens

Two upper platens will close automatically to the preset gap setting with the touch of one button. Air cylinder system provides quiet, simple, trouble-free operation of the upper platen. As a safety feature, platen will automatically open at loss of power, or if an obstruction is detected.

Precise Automatic Gapping

Solid platform with 3-point reference plane and fixed (home) reference point. Once programmed, the upper platen automatically achieves accurate and consistent gaps, every time. Precise, repeatable gapping assures product safety and better quality finished product.

Cooking Zones

Three separately controlled cooking positions. Three independent heating elements in the lower cooking surface, and two in the upper platen, assures even temperatures and quick recovery.

Side-To-Side Release Material

Protects entire upper platen cooking surface and makes cleaning easy. Improved install and removal process away from hot surfaces.

Patty Cook Position Placement Guide

Lower cooking surface is etched for a permanent patty placement guide for two-sided cooking.



Rockton, Illinois 61072
800-255-0626
Phone 815-624-8333 Fax 815-624-8000
www.taylor-company.com
e-mail: info@taylor-company.com

International Office
Taylor Company S.r.l.
Roma, Italy
Tel: **+39-06-420-12002** Fax: +39-06-420-12034
e-mail: romeoff@taylor-company.com

ISO 9001:2000
Registered Firm

C812 Electric Two-Sided Grill

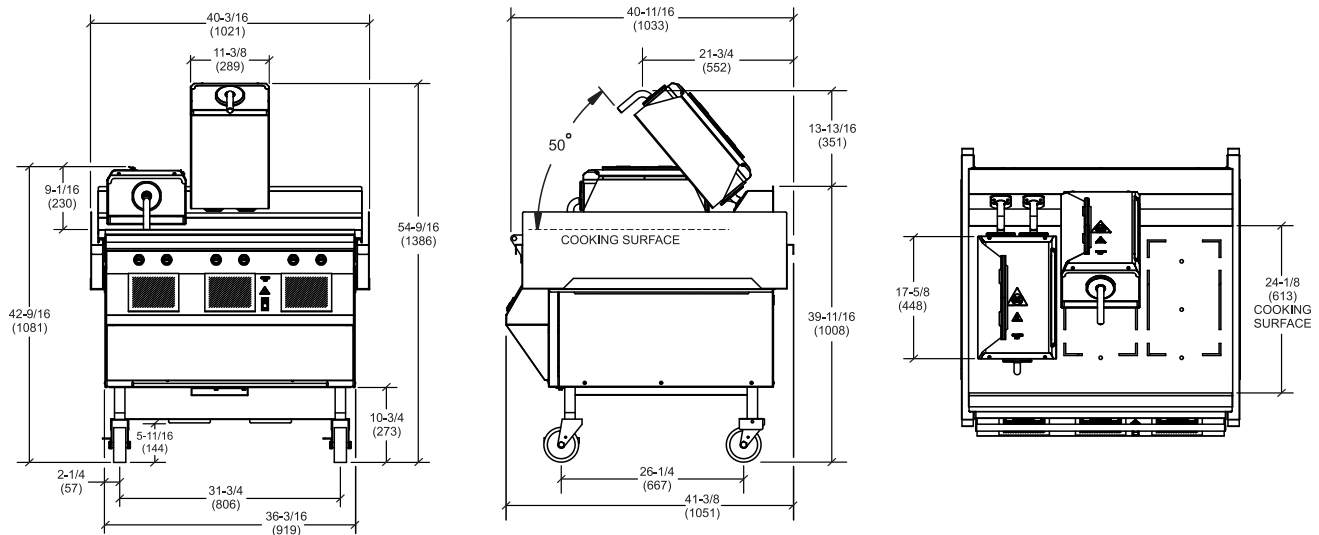

DIMENSIONS IN PARENTHESES ARE IN MILLIMETERS

Weights	lbs.	kgs.
Net	773	350.6
Crated	900	408
	cu. ft.	cu. m.
Volume	53.7	1.52

Dimensions	in.	mm.
Width	40-3/16	1021
Depth	41-3/8	1051
Height	38-3/8 - 44-3/8	975 to 1127
Floor Clearance	7-1/4 to 13-1/4	184 to 336

Casters may be adjusted.

Electrical	Amps Per Cord	Cord Supplied with NEMA Plug	Cord Length
208/60/3	38 (2)	15-50P (2)	7' (2.13 m)

*Other electrical characteristics may be available.
(For exact electrical information, always refer to the data label of the unit.)*

Specifications

Electrical

Two dedicated electrical connections are required. See the Electrical chart for the proper electrical requirements. Manufactured to be permanently connected. Consult your local Taylor distributor for receptacle specifications as local codes allow. Restraining cable included.

Accessories

- Two; side grease cans
- One box of 9 release sheets; includes clips and retainer
- One Squeegee
- Grill Cleaner (1qt)

Options

- Cleaning Pads (20 qty.)
- Gap Gage (0.255)
- Grill Scraper
- Scotch-Brite Pad Holder
- Tool Holder

Continuing research results in steady improvements; therefore, these specifications are subject to change without notice.



Taylor Company,
A Division of Carrier Commercial Refrigeration, Inc.
Rockton, Illinois 61072
815-624-8333 **800-255-0626** Fax 815-624-8000

Printed in U.S.A.

073671-ADV 10/10