

C707

Soft Serve Freezer

Single Flavor

Features

Offer all the popular soft serve variations from low or non-fat ice creams to custards, yogurt and sorbet.

Freezing Cylinder

One, 3.4 quart (3.2 liter).

Mix Hopper

One, 20 quart (18.9 liter). Separate hopper refrigeration (SHR) maintains mix below 41°F (5°C) during Auto and Standby modes.

Indicator Lights

Mix Low light alerts operator to add mix. Audible alarm may be enabled to sound when mix is low. When the Mix Out light flashes, the unit shuts down automatically to prevent damage.

Electronic Controls

Softech™ is our exclusive microprocessor based master control that regulates refrigeration by measuring product viscosity to maintain consistent quality.

Standby

During long no-use periods, the standby feature maintains safe product temperatures in the mix hopper and freezing cylinder.

Digital Temperature Indicator

Hopper temperature is displayed to assure safe product temperatures. Indicator may be switched from Fahrenheit to Celsius temperature display.

Door Interlock System

Protects the operator from injury as the beater will not operate without the dispensing door in place.



Optional cart with front opening door



Optional cart with rear door for front mount syrup rail.



Optional top air discharge chute

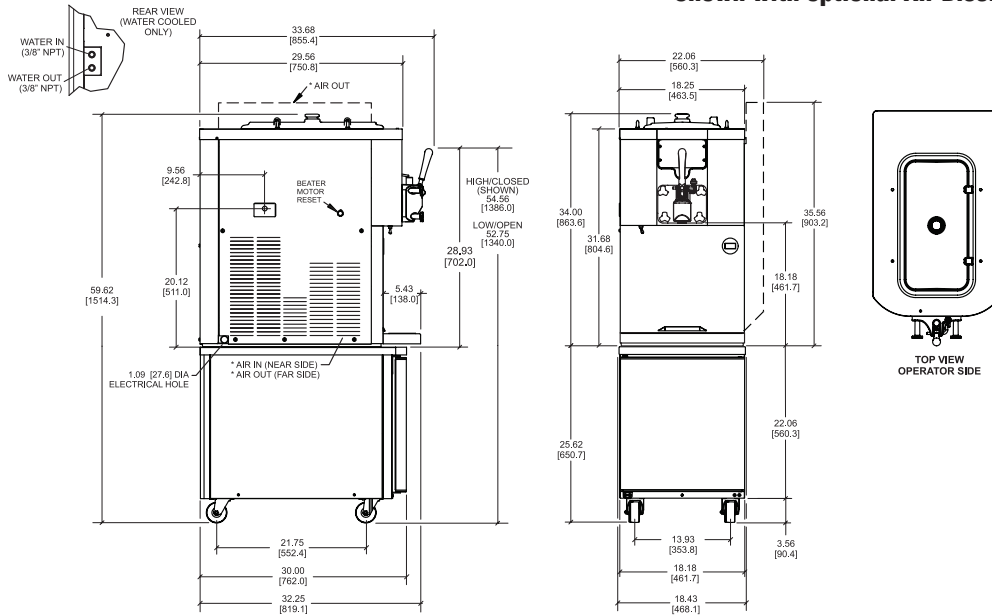

NOTE: * (AIR COOLED ONLY) FIGURES IN BRACKETS INDICATE MILLIMETERS / DECIMAL AND FRACTIONAL DIMENSIONS EQUAL TO (PLUS OR MINUS 1/16 INCH [1.5mm]).

Weights	lbs.	kgs.
Net	390	176.9
Crated	412	186.9
Volume	cu. ft.	cu. m.
	35.0	0.99
Dimensions	in.	mm.
Width	18-1/4	464
Depth	32-1/4	819
Height	34	864
Counter Clearance	---	---

*Designed to rest on a plastic pad directly on the counter top or optional cart.

Electrical	Maximum Fuse Size	Minimum Circuit Ampacity	Poles (P) Wires (W)
208-230/60/1 Air	35	25	2P 3W
208-230/60/1 Water	35	25	2P 3W
208-230/60/3 Air	20	16	3P 4W
208-230/60/3 Water	20	16	3P 4W
220-240/50/1 Air	25	21	2P 3W
380-415/50/3N~ Air	10	8	4P 5W

This unit may be manufactured in other electrical characteristics and may have additional regulatory agency approvals. Consult the local Taylor Distributor for other electrical characteristics and agency approvals based on specific electrical and country requirements.

(For exact electrical information and approval marks, always refer to the data label of the unit.)

Continuing research results in steady improvements; therefore, these specifications are subject to change without notice.

Bidding Specs

Electrical: Volt _____ Hz _____ ph _____
 Neutral: Yes No **Cooling:** Air Water NA

Options: _____

Authorized Taylor Distributor

Specifications

Electrical

One dedicated electrical connection is required. See the Electrical chart for the proper electrical requirements. Manufactured to be permanently connected. Consult your local Taylor distributor for cord & receptacle specifications as local codes allow.

Beater Motor

One, 1.5 HP.

Refrigeration System

One, 9,500 BTU/hr. R404A. Separate Hopper Refrigeration (SHR), One, 400 BTU/hr. R134a. (BTUs may vary depending on compressor used.)

Air Cooled

Minimum 6" (152 mm) on both sides and place the back of the unit against a wall to prevent recirculation of warm air. Minimum air clearances must be met to assure adequate air flow for optimum performance. Optional air discharge chute directs heated air exhaust upwards. No clearance required on right side if air discharge chute is used.

Water Cooled

Water inlet and drain connections out rear panel 3/8" FPT.

Options

- Cart with casters-height to top of hopper cover: 59-5/8" (1515 mm)
- Cone Dispenser
- Decals - Vanilla or Flavor Burst Cone
- Hopper Agitator
- Hopper Locks
- Legs - [increase height of unit by 4-1/4" (108 mm)]
- Syrup Rail (front mount requires special cart with rear door)
- Syrup Rail Kit (side mount)
- Top Air Discharge Chute (air cooled only)

C201 Cart Weights:

Net: 150 lbs. (68.0 kg)

Crated: 171 lbs. (77.6 kg) 14.5 cu. ft. (0.41 cu. m.)



750 N. Blackhawk Blvd.
 Rockton, Illinois 61072
www.taylor-company.com